

PKCELL

SHENZHEN PKCELL BATTERY CO., LTD

R14P

Specifications for Non-Hg Super heavy duty Battery

Compiled by: Zhijiang Li

Checked by: Beiqian Ding

Date: January 1, 2000

Product Model: PKCELL-R14P-C

Website: www.pkcell.net

E-mail: pkcell@pkcell.net

(The manufacturer keeps privilege to modify the product specifications and data without notice)

Specifications for Non-Hg R14P Super heavy duty Battery

1 Product Model

R14P C AM-2

2 Chemical System

Super heavy duty battery
(Non-Hg, Non-Cadmium)

3 Specification (mm)

Total Length A: 48.6 ~ 50.0
External diameterφ: 24.9 ~ 26.2

4 Nominal Voltage: 1.5V

5 Storage Performance

After 12 months storage at specified conditions, discharge capacity should be no less than 80% of the original discharge capacity.

6 Mercury Content: Less than 1ppm

7 Electrical Performance (3.9Ω 0.3S 20±2℃)

/	Open Circuit Voltage (V)	Closed Circuit Voltage (V)	Short Circuit Current (A)
Initial period	Above 1.65	Above 1.50	Above 6
After 12 months	Above 1.60	Above 1.45	Above 5

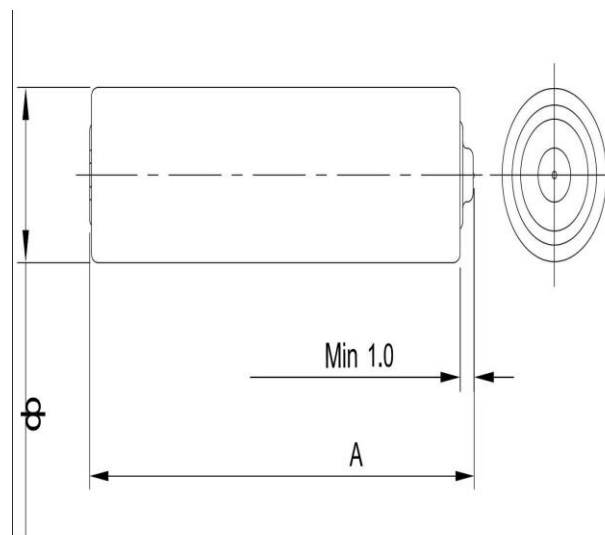

8. Discharge Capacity (20±2℃, RH: 45%~75%)

Standard	Discharge Condition			Average Minimum Discharge time		
	discharge Load	Discharge Time	E.P.(V)	New Battery	After 3 mths at 45 °C	after 12 mths.at room temperature
IEC	20Ω	4H/D	0.9V	34H	32H	32H
IEC	3.9Ω	24H/D	0.9V	260min	248min	248min

Pls check the sketch map as following

9. Performance

(1)Spillage proof test at over-discharge

The number of samples: 9

Test condition: 20±2℃,relative humidity 45%-75%

Test method: 3.9Ωcontinuous discharge at 0.35V

Requirements: no spillage at eyesight, the distortion of total height of the battery will not exceed 0.2mm, the max allowable value.

Standard: 0/9

(2) Spillage proof test at high temperature

The number of samples: 20

Test condition: $45\pm 2^{\circ}\text{C}$, relative humidity 85%-95%

Test method: Under the prescriptive test conditions, the samples are stored for 30 days. Then they are took out and placed under $20\pm 2^{\circ}\text{C}$, relative humidity 45%-75% conditions for 4 to 24 hours for observation.

Requirements: no spillage at eyesight, the distortion of total height of the battery will not exceed 0.2mm, the max allowable value.

Standard: 0/20

10. Safety performance

The performance of explosion protection due to the external short circuit

The number of samples: 10

Test condition: $20\pm 2^{\circ}\text{C}$, relative humidity 45%-75%

Test method: Under the prescriptive test conditions, external short circuit lasts for 24 hours

Requirements: no separation occurs between the negative terminal and the body of the battery.

Standard: 0/10

11. Guarantee period: 2 years

12. Label on the product:

The following items are labeling on the battery surface:

(1) Model: R14P

(2) Trademark: PKCELL

(3) Nominal voltage: 1.5V

(4) Polarity: “+”“—”

(5) Precautions: Do not attempt to recharge a battery, and Do not dispose of batteries in fire.

(6) Manufacturer : Pkcell

13. Precautions of use:

(1) Since the battery is not manufactured for recharging, there are risks of electrolyte leakage or causing damage to the device if the battery is charged.

(2) The battery shall be installed with its “+” and “-” polarity in correct position, otherwise may cause short-circuit.

(3) Short-circuit, heating, disposing of into fire and disassembling the battery are prohibited.

(4) Battery cannot be forced discharged, which lead to excess gassing and may result in bulging leakage and de-crimping of cap.

- (5) New and used batteries cannot be used at the same time,when replaced batteries recommend to replace all and with the same brand type.
- (6) Exhausted batteries should be removed from compartment to prevent over-discharge,which cause leakgae damage to the device.
- (7) Direct soldering is not allowed,which will damage the battery.
- (8) Battery should be kept out of the reach of children to prevent swallow,in case of accident should contact physician at once.

Schematic diagram of discharge:

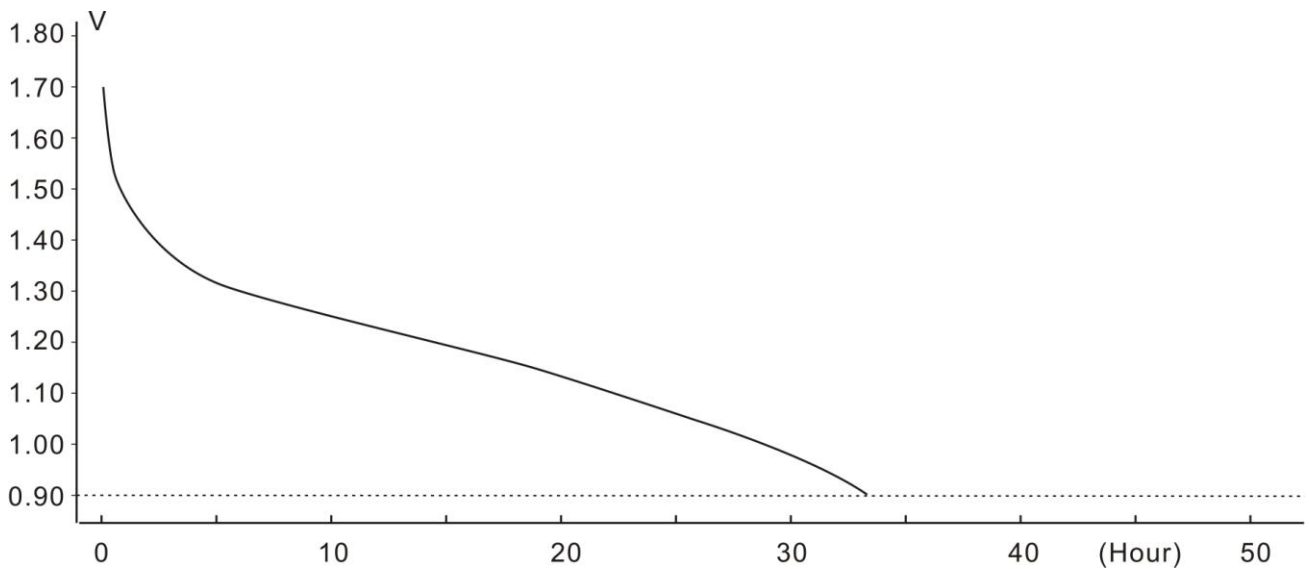

discharge Load: 20Ω

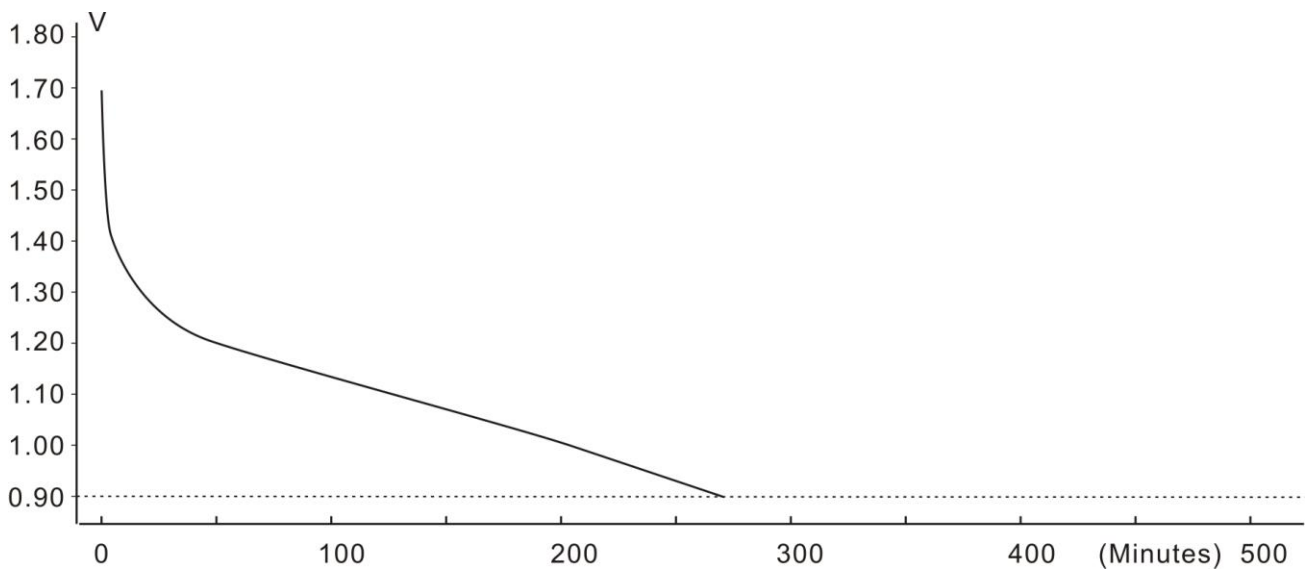

discharge Load: 3.9Ω